

Network layer: Overview

- ❑ Network layer functions
- ❑ IP
- ❑ Routing and forwarding

Network layer functions

- ❑ Transport packet from sending to receiving hosts
- ❑ Network layer protocols in *every* host, router

Three important functions:

- ❑ *Path determination*: route taken by packets from source to dest. *Routing algorithms*
- ❑ *Switching*: move packets from router's input to appropriate router output

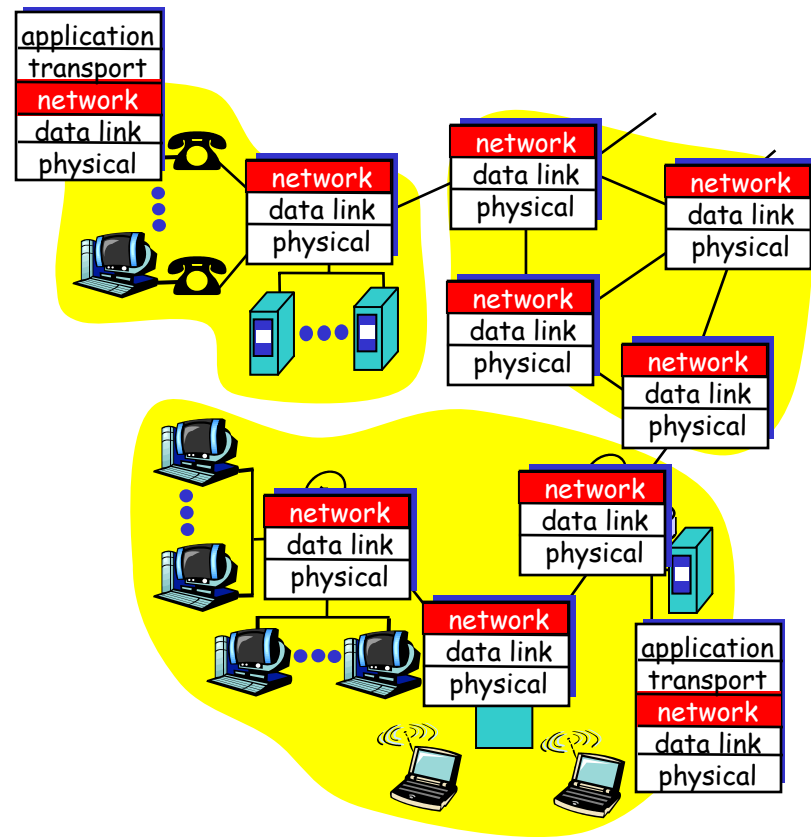

IP addressing

- ❑ IP address: 32-bit identifier for host, router *interface*
- ❑ *Interface*: connection between host, router and physical link
 - Routers typically have multiple interfaces
 - Host may have multiple interfaces
 - IP addresses associated with interface, not host, router

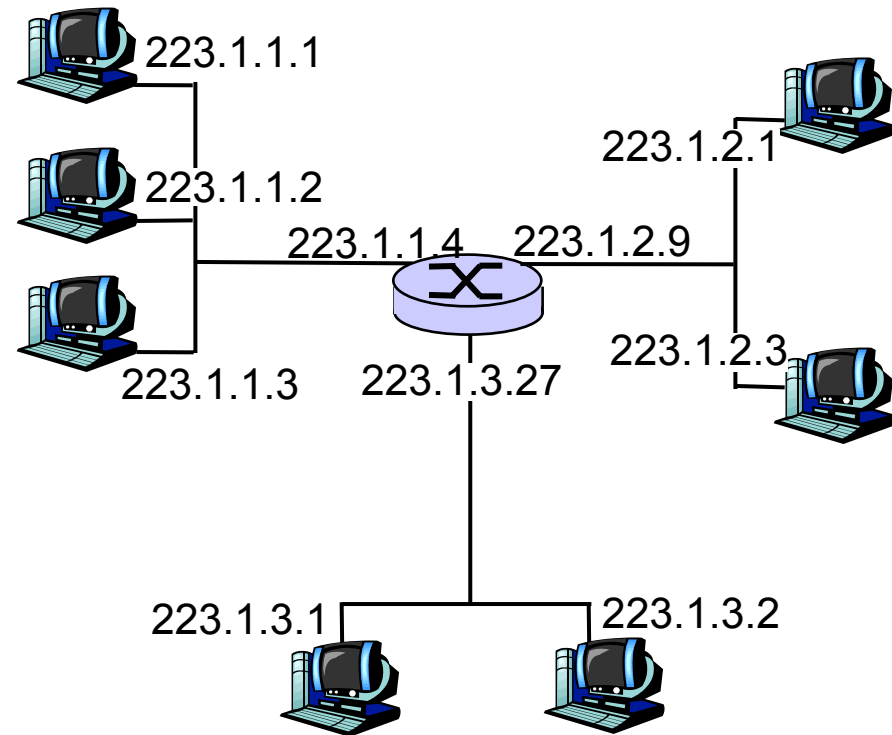

$$223.1.1.1 = \underbrace{11011111}_{223} \underbrace{00000001}_{1} \underbrace{00000001}_{1} \underbrace{00000001}_{1}$$

IP addressing (2)

- ❑ IP address:
 - Network part (high order bits)
 - Host part (low order bits)
- ❑ *What's a network?*
(from IP address perspective)
 - Device interfaces with same network part of IP address
 - Can physically reach each other without intervening router

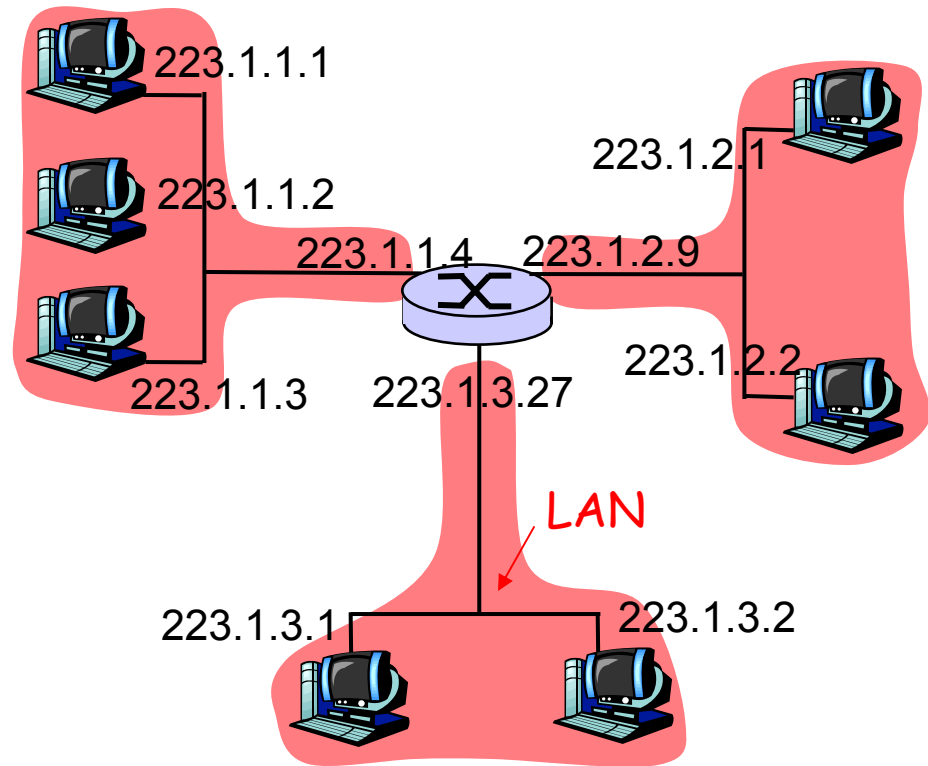

network consisting of 3 IP networks
(for IP addresses starting with 223,
first 24 bits are network address)

IP addressing (3)

How to find the networks?

- ❑ Detach each interface from router, host
- ❑ Create "islands" of isolated networks

Interconnected system consisting of six networks

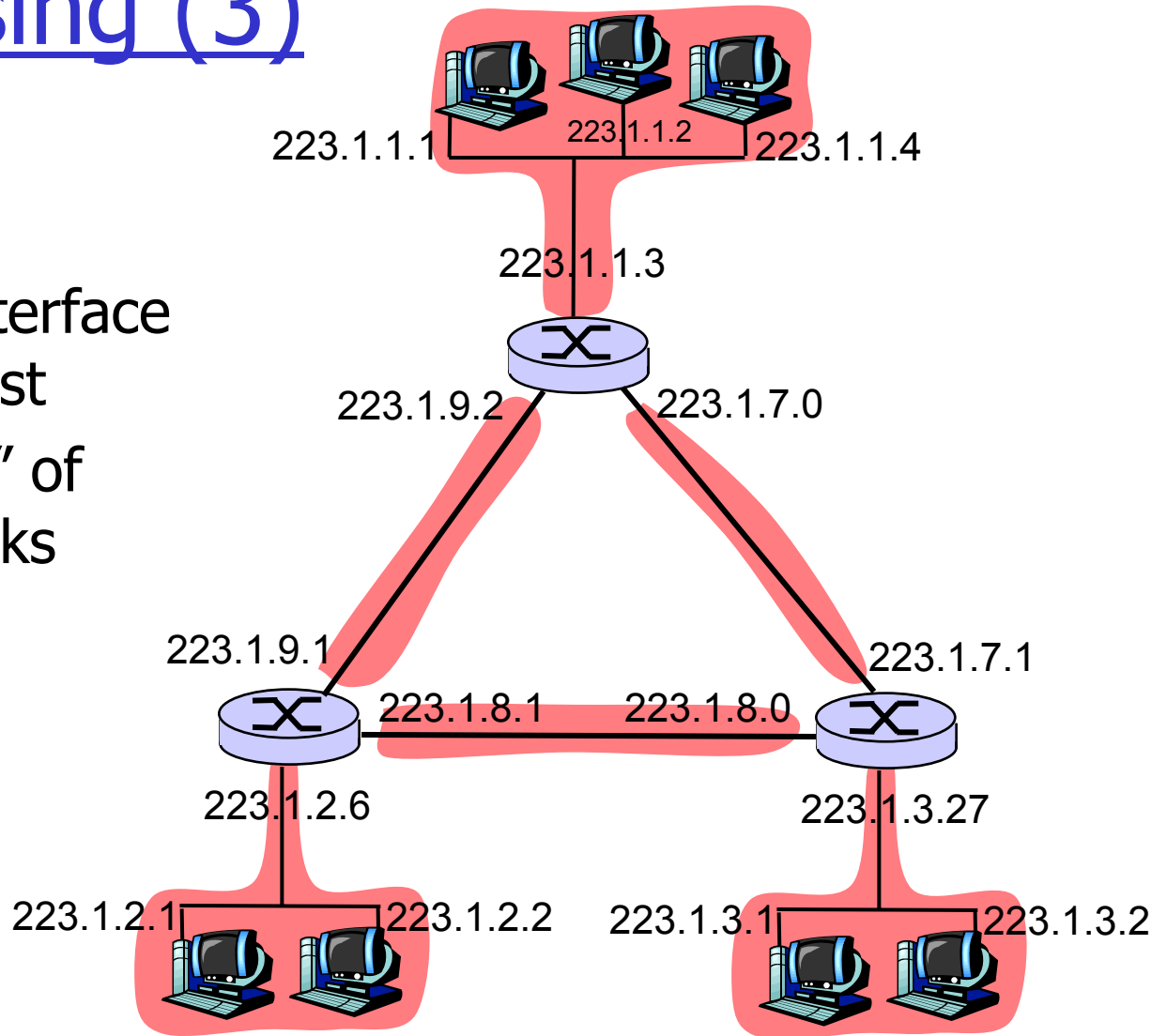

IP networks: Subnets

- ❑ Sub divide address space
 - Network part
 - Host address
- ❑ Address format: **a.b.c.d/x**, where x is # bits in subnet portion of address

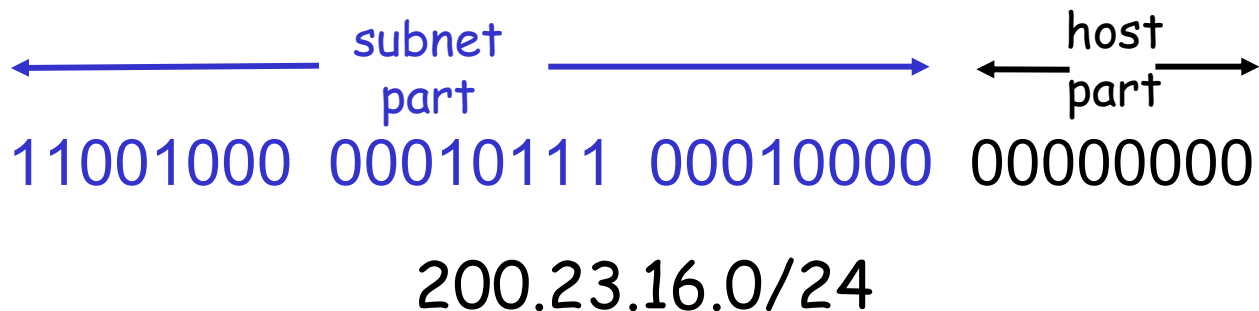

Fixed subnetting (classful)

class

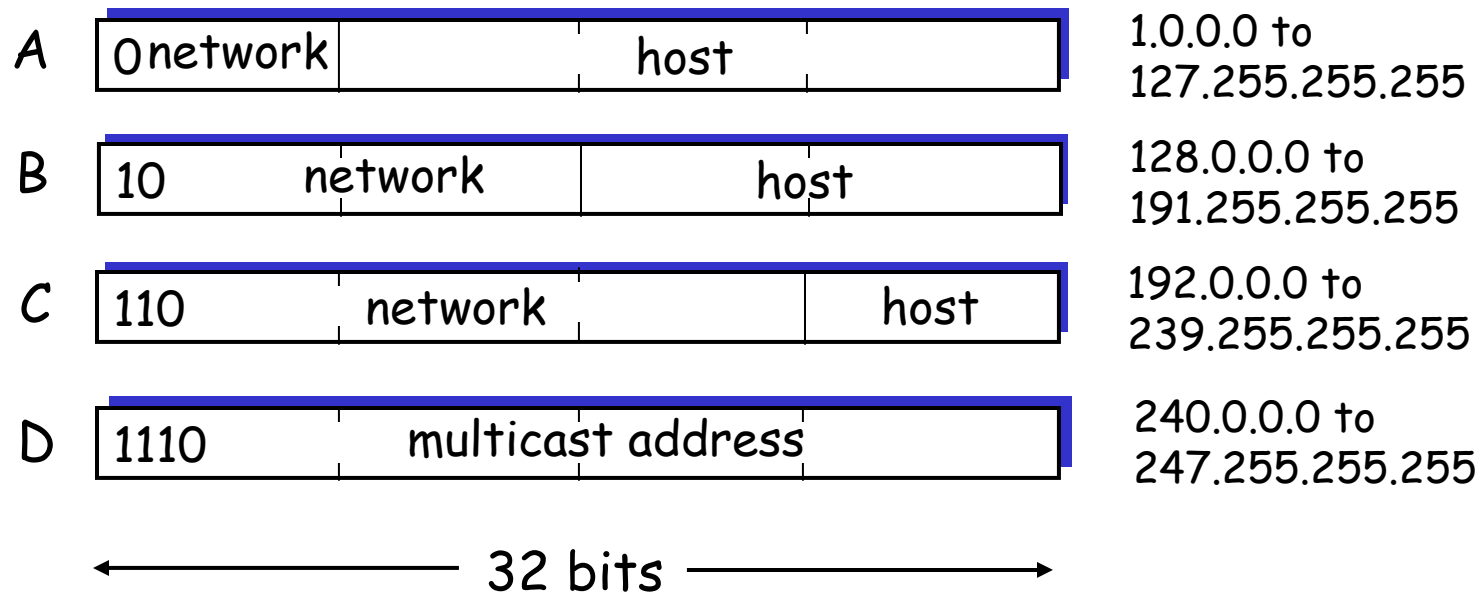

Address management

- ❑ Problem: we are running out of networks
- ❑ Solution
 - **Subnetting**
 - **CIDR** (Classless Inter Domain Routing)

CIDR

- ❑ Classless InterDomain Routing
- ❑ Class A is too large, Class C is too small
- ❑ Everyone has a Class B address!!!

- ❑ Solution: sites are given contiguous blocks of class-C addresses (256 addresses each) and a mask or parts of former class A/B networks.

CIDR

CIDR: Classless InterDomain Routing

- ❑ Subnet portion of address of arbitrary length
- ❑ Address format: **a.b.c.d/x**, where x is # bits in subnet portion of address

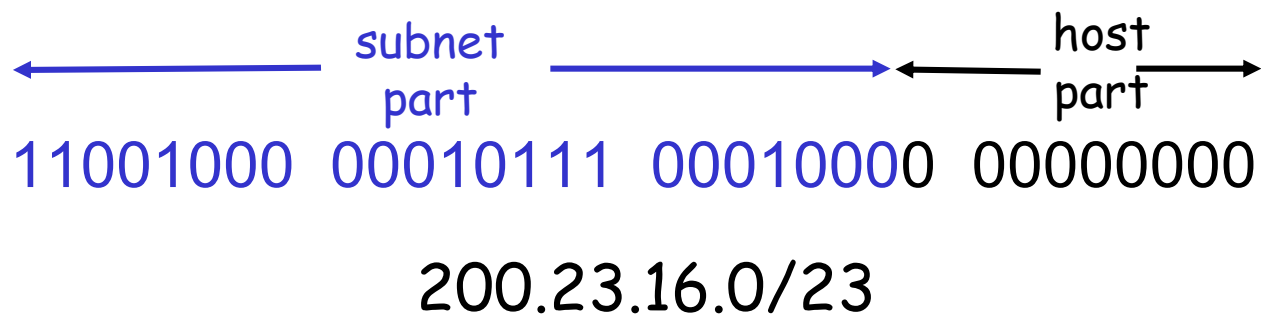

Hierarchical address structure

□ Recall: CIDR

128.119.48.12/18 = $\overbrace{10000000\ 01110111\ 00}^{18\ \text{relevant bits}}110000\ 00001100$

- High order bits form the **prefix**
- Once inside the network, can **subnet**: divide remaining bits
- Subnet example:

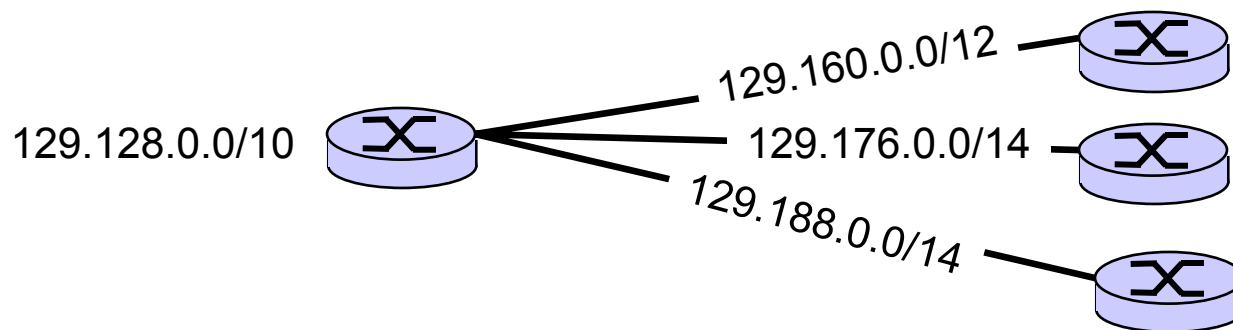

Note: Picture shows prefix masks, not interface addrs!

□ Forwarding decision: longest prefix match

Forwarding vs. Routing

- ❑ **Forwarding:** the process of moving packets from input to output
 - The forwarding table
 - Information in the packet

 - ❑ **Routing:** process by which the forwarding table is built and maintained
 - One or more routing protocols
 - Procedures (algorithms) to convert routing info to forwarding table.
- (Much more later ...)

Forwarding with CIDR

- ❑ Packet should be sent towards the interface with the **longest matching prefix**

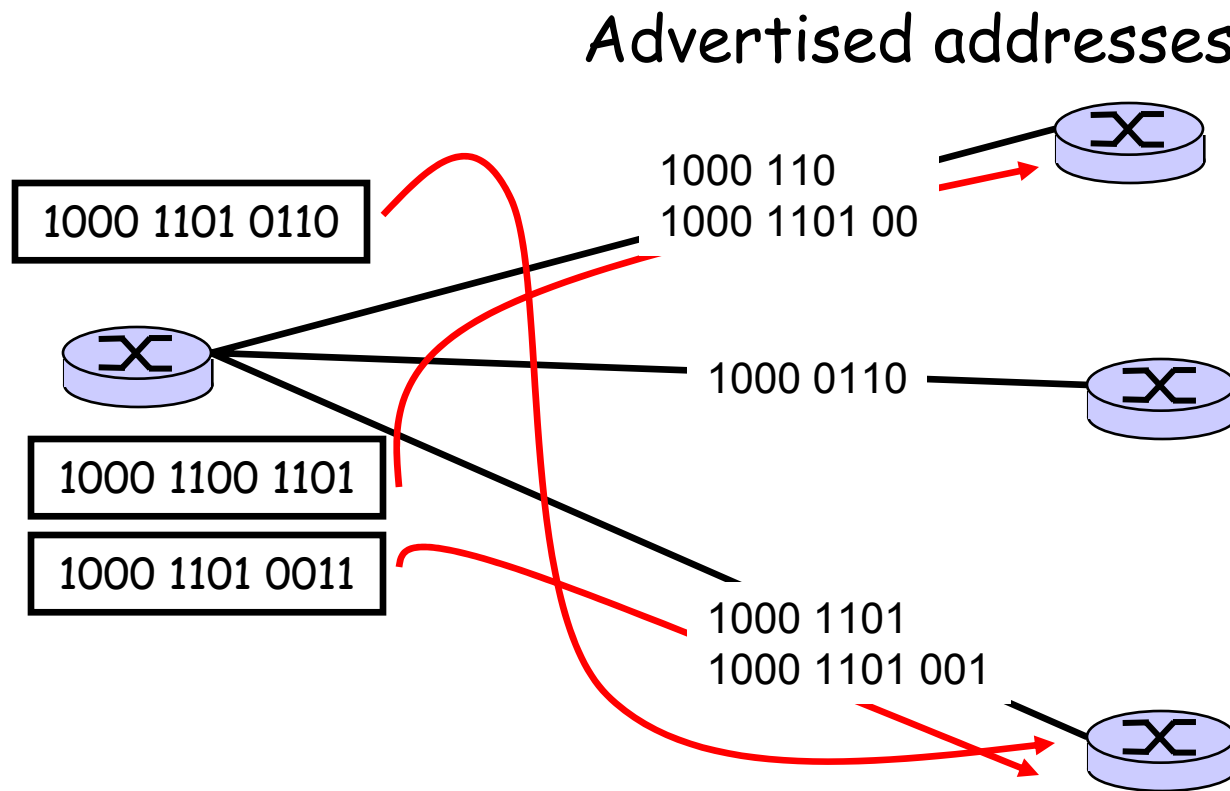

Lookup (longest prefix match):

- ❑ Forwarding table:
<Network>/<mask> <next-hop>
- ❑ IP Packets: destination IP address
 - Find next-hop
- ❑ Example:

Forwarding table

134.96.252.0/24	A
134.96.0.0/16	C
134.96.240.0/20	B
134.96.252.192/28	B
134.96.252.128/28	A

Packets

134.96.252.200
134.96.254.2
134.96.239.200
134.97.239.200
134.96.252.191

IPv4 datagram format

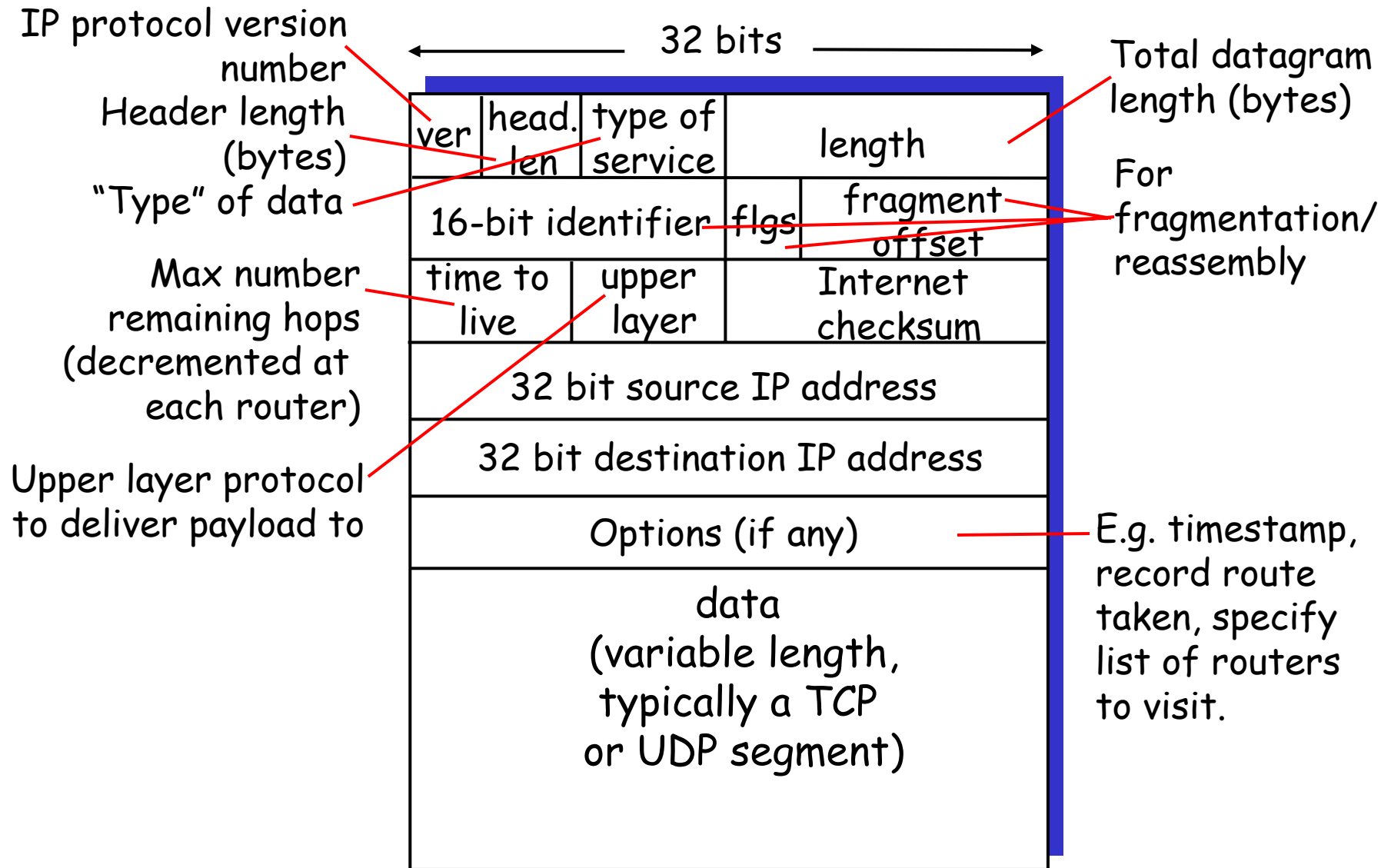

ICMP: Internet Control Message Protocol

- ❑ Used by hosts, routers, gateways to communication network-level information
 - Error reporting: unreachable host, network, port, protocol
 - Echo request/reply (used by ping)
- ❑ Network-layer "above" IP:
 - ICMP msgs carried in IP datagrams
- ❑ **ICMP message:** type, code plus first 8 bytes of IP datagram causing error

<u>Type</u>	<u>Code</u>	<u>description</u>
0	0	echo reply (ping)
3	0	dest network unreachable
3	1	dest host unreachable
3	2	dest protocol unreachable
3	3	dest port unreachable
3	6	dest network unknown
3	7	dest host unknown
4	0	source quench (congestion control – not used)
8	0	echo request (ping)
9	0	route advertisement
10	0	router discovery
11	0	TTL expired
12	0	bad IP header

Network layer: Summary

- ❑ Network layer functions
- ❑ IP
- ❑ Routing and forwarding