

RIP (Routing Information Protocol)

RIP (Routing Information Protocol)

- ❑ Distance vector algorithm
- ❑ Included in BSD-UNIX Distribution in 1982
- ❑ Distance metric: # of hops (max = 15 hops)

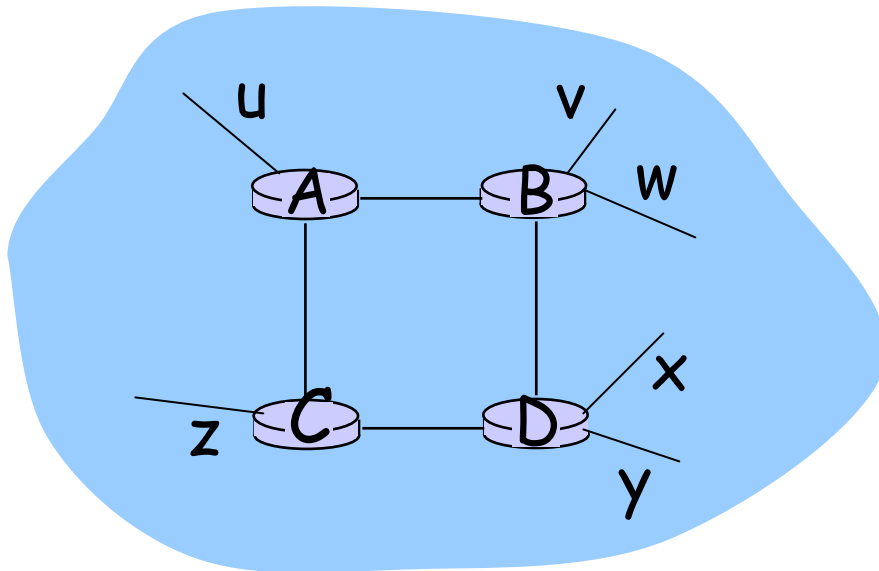

From router A to subsets:

<u>destination</u>	<u>hops</u>
u	1
v	2
w	2
x	3
y	3
z	2

RIP advertisements

- ❑ Distance vectors: exchanged among neighbors every 30 sec via Response Message (also called **advertisement**)
- ❑ Each advertisement: list of up to 25 destination nets within AS

RIP: Link Failure And Recovery

If no advertisement heard after 180 sec,
neighbor/link declared dead

- Routes via the neighbor are invalidated
- New advertisements sent to neighbors
- Neighbors in turn send out new advertisements (if their tables changed)
- Link failure info quickly propagates to entire net
- Poison reverse used to prevent ping-pong loops (infinite distance = 16 hops)

RIP Table Processing

- ❑ RIP routing tables managed by an **application process** [Unix: route-d (daemon)]
- ❑ Advertisements encapsulated in UDP packets (no reliable delivery required)
- ❑ Advertisements are periodically repeated

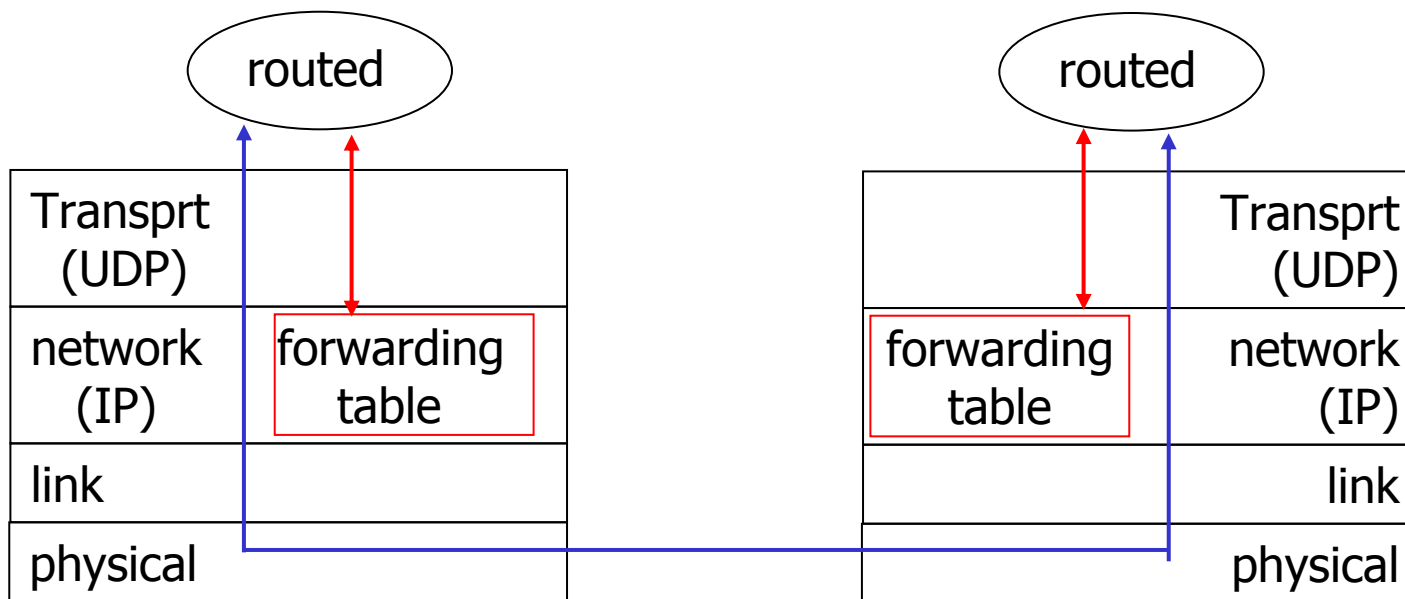

RIP Table Example

Router: *giroflee.eurocom.fr*

Destination	Gateway	Flags	Ref	Use	Interface
127.0.0.1	127.0.0.1	UH	0	26492	lo0
192.168.2.	192.168.2.5	U	2	13	fa0
193.55.114.	193.55.114.6	U	3	58503	le0
192.168.3.	192.168.3.5	U	2	25	qaa0
224.0.0.0	193.55.114.6	U	3	0	le0
default	193.55.114.129	UG	0	143454	

- ❑ Three attached class C networks (LANs)
- ❑ Router only knows routes to attached LANs
- ❑ Default router used to “go up”
- ❑ Route multicast address: 224.0.0.0
- ❑ Loopback interface

How to avoid Count-to-Infinity

- ❑ Split Horizon
- ❑ Split Horizon with Poisoned Reverse
- ❑ Triggered Updates
 - After metric change: send update immediately
- ❑ Holddown Timer (Cisco)
 - After invalidation of route: for some seconds ignore all updates for route