

Intrusion Detection System

Time Machine

Dynamic Application Detection

NIDS: A generic problems

- **Application identification**
 - Only by port number!
 - Yet **applications use arbitrary ports**
 - **Benign reasons**
 - Lack administrator privileges
 - Circumvention of firewall, e.g., Skype
 - Application tunnels
 - **Malicious intend**
 - Evasion of security monitoring
 - E.g.: IRC based botnets on ports other than 666x/tcp
 - E.g.: ftp servers on ports other than 21/tcp

Applications on non-standard ports

- ❑ Data (Oct. 2005):
 - 24 hour full packet trace from Münchner WissenschaftsNetz (MWN)
 - 3.2 TB of data in 6.3 billion pkts, 137M connections

- ❑ Application signatures from I7-filter system
- ❑ Focus on HTTP, IRC, FTP, SMTP

Ports accounting > 1% of conns.

Port		% Conns	% Success	% Payload
Web	80	70.82%	68.13%	72.59%
	445	3.53%	0.01%	0.00%
Web	443	2.34%	2.08%	1.29%
SSH	22	2.12%	1.75%	1.71%
Mail	25	1.85%	1.05%	1.71%
	1042	1.66%	0.00%	0.00%
	1433	1.06%	0.00%	0.00%
	135	1.04%	0.00%	0.00%
	< 1024	83.68%	73.73%	79.05%
	> 1024	16.32%	4.08%	20.95%

Signature-based app. detection

- ❑ Port information offers no information for ports > 1024
- ❑ I7-filter system application signatures
- ❑ HTTP highly attractive for hiding other applications
- ❑ Most successful conns. trigger expected signature
- ❑ FTP higher percentage of false negatives

Method	HTTP	IRC	FTP	SMTP
Port (succ.)	93,429K	75,876	151,700	1,447K
Signature	94,326K	73,962	125,296	1,416K
expected port	92,228K	71,467	98,017	1,415K
other port	2,126K	2,495	27,279	265

Signature detection: Well known ports

- ❑ Some connections trigger more than one signature
- ❑ Not yet wide-spread abuse
- ❑ But some inappropriate use of well known ports

Port	HTTP	IRC	SMTP	Other	No match
80	92,228,291	59	0	41,086	1,158,977
666x	1,217	71,650	0	4,238	524
25	459	2	1,415,428	195	31,889

Architecture for dynamic analysis

□ Goals

- Detection scheme independence
- Dynamic analysis
- Modularity
- Efficiency
- Customizability

□ Design (USENIX Security'06)

- Dynamic processing path
- Per connection dynamic analyzer trees

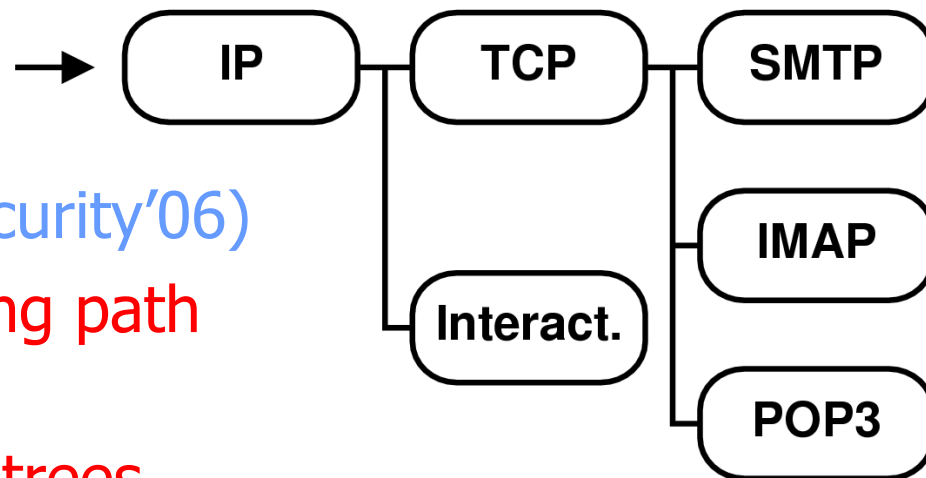

Reliable detection of non-standard ports

- UCB: 1 day

	internal	remote
FTP servers:	6	17
HTTP servers:	568	54,830
IRC servers:	2	33
SMTP servers:	8	8

- MWN similar

- Non-standard port connection
 - UCB: 99% HTTP (28% Gnutella, 22% Apache)
 - MWN: 92% HTTP (21% BitTorrent, 20% Gnutella), 7% FTP
 - Two open HTTP proxy detected: now closed
 - SMTP server that allowed relay: now closed

Detecting IRC-based Botnets

□ Idea

- Botnets like IRC protocol (remote control features)
- Botnet detector on top of IRC analyser
 - Checks client nickname for typical patterns
 - Checks channel topics for typical botnet commands
 - Checks if new clients connect with IRC to identified bot-servers

□ Results

- MWN:
 - > 100 distinct IPs with Botnet clients
 - Now part of a automatic prevention system
- UCB:
 - 15 distinct IPs

Summary: Dynamic app. analysis

❑ Ideas:

- Dynamic processing path
- Per connection dynamic analyzer trees

- ❑ Operational at three large-scale networks
- ❑ Detected significant number of security incidents
- ❑ Bot-detection now automatically blocks IP